

ISSN 2518-1467 (Online),
ISSN 1991-3494 (Print)

ҚАЗАҚСТАН РЕСПУБЛИКАСЫ
ҰЛТТЫҚ ҒЫЛЫМ АКАДЕМИЯСЫНЫҢ

Х А Б А Р Ш Ы С Ы

ВЕСТНИК

НАЦИОНАЛЬНОЙ АКАДЕМИИ НАУК
РЕСПУБЛИКИ КАЗАХСТАН

THE BULLETIN

OF THE NATIONAL ACADEMY OF SCIENCES
OF THE REPUBLIC OF KAZAKHSTAN

1944 ЖЫЛДАН ШЫҒА БАСТАҒАН
ИЗДАЕТСЯ С 1944 ГОДА
PUBLISHED SINCE 1944

1

АЛМАТЫ
АЛМАТЫ
ALMATY

2018

JANUARY
ЯНВАРЬ
ҚАҢТАР

NAS RK is pleased to announce that Bulletin of NAS RK scientific journal has been accepted for indexing in the Emerging Sources Citation Index, a new edition of Web of Science. Content in this index is under consideration by Clarivate Analytics to be accepted in the Science Citation Index Expanded, the Social Sciences Citation Index, and the Arts & Humanities Citation Index. The quality and depth of content Web of Science offers to researchers, authors, publishers, and institutions sets it apart from other research databases. The inclusion of Bulletin of NAS RK in the Emerging Sources Citation Index demonstrates our dedication to providing the most relevant and influential multidiscipline content to our community.

Қазақстан Республикасы Ұлттық ғылым академиясы "ҚР ҰҒА Хабаршысы" ғылыми журналының Web of Science-тің жаңаланған нұсқасы Emerging Sources Citation Index-те индекстелуге қабылданғанын хабарлайды. Бұл индекстелу барысында Clarivate Analytics компаниясы журналды одан әрі the Science Citation Index Expanded, the Social Sciences Citation Index және the Arts & Humanities Citation Index-ке қабылдау мәселесін қарастыруда. Web of Science зерттеушілер, авторлар, баспашылар мен мекемелерге контент тереңдігі мен сапасын ұсынады. ҚР ҰҒА Хабаршысының Emerging Sources Citation Index-ке енуі біздің қоғамдастық үшін ең өзекті және беделді мультидисциплинарлы контентке адалдығымызды білдіреді.

НАН РК сообщает, что научный журнал «Вестник НАН РК» был принят для индексирования в Emerging Sources Citation Index, обновленной версии Web of Science. Содержание в этом индексировании находится в стадии рассмотрения компанией Clarivate Analytics для дальнейшего принятия журнала в the Science Citation Index Expanded, the Social Sciences Citation Index и the Arts & Humanities Citation Index. Web of Science предлагает качество и глубину контента для исследователей, авторов, издателей и учреждений. Включение Вестника НАН РК в Emerging Sources Citation Index демонстрирует нашу приверженность к наиболее актуальному и влиятельному мультидисциплинарному контенту для нашего сообщества.

Б а с р е д а к т о р ы

х. ғ. д., проф., ҚР ҰҒА академигі

М. Ж. Жұрынов

Р е д а к ц и я а л қ а с ы:

Абиев Р.Ш. проф. (Ресей)
Абишев М.Е. проф., корр.-мүшесі (Қазақстан)
Аврамов К.В. проф. (Украина)
Аппель Юрген проф. (Германия)
Баймуқанов Д.А. проф., корр.-мүшесі (Қазақстан)
Байпақов К.М. проф., академик (Қазақстан)
Байтулин И.О. проф., академик (Қазақстан)
Банас Иозеф проф. (Польша)
Берсимбаев Р.И. проф., академик (Қазақстан)
Велихов Е.П. проф., РҒА академигі (Ресей)
Гашимзаде Ф. проф., академик (Әзірбайжан)
Гончарук В.В. проф., академик (Украина)
Давлетов А.Е. проф., корр.-мүшесі (Қазақстан)
Джрбашян Р.Т. проф., академик (Армения)
Қалимолдаев М.Н. проф., академик (Қазақстан), бас ред. орынбасары
Лаверов Н.П. проф., академик РАН (Россия)
Лупашку Ф. проф., корр.-мүшесі (Молдова)
Мохд Хасан Селамат проф. (Малайзия)
Мырхалықов Ж.У. проф., академик (Қазақстан)
Новак Изабелла проф. (Польша)
Огарь Н.П. проф., корр.-мүшесі (Қазақстан)
Полещук О.Х. проф. (Ресей)
Поняев А.И. проф. (Ресей)
Сагиян А.С. проф., академик (Армения)
Сатубалдин С.С. проф., академик (Қазақстан)
Таткеева Г.Г. проф., корр.-мүшесі (Қазақстан)
Умбетаев И. проф., академик (Қазақстан)
Хрипунов Г.С. проф. (Украина)
Юлдашбаев Ю.А. проф., РҒА корр.-мүшесі (Ресей)
Якубова М.М. проф., академик (Тәжікстан)

«Қазақстан Республикасы Ұлттық ғылым академиясының Хабаршысы».

ISSN 2518-1467 (Online),

ISSN 1991-3494 (Print)

Меншіктенуші: «Қазақстан Республикасының Ұлттық ғылым академиясы»РҚБ (Алматы қ.)

Қазақстан республикасының Мәдениет пен ақпарат министрлігінің Ақпарат және мұрағат комитетінде
01.06.2006 ж. берілген №5551-Ж мерзімдік басылым тіркеуіне қойылу туралы куәлік

Мерзімділігі: жылына 6 рет.

Тиражы: 2000 дана.

Редакцияның мекенжайы: 050010, Алматы қ., Шевченко көш., 28, 219 бөл., 220, тел.: 272-13-19, 272-13-18,
www: nauka-nanrk.kz, bulletin-science.kz

© Қазақстан Республикасының Ұлттық ғылым академиясы, 2018

Типографияның мекенжайы: «Аруна» ЖК, Алматы қ., Муратбаева көш., 75.

Г л а в н ы й р е д а к т о р
д. х. н., проф. академик НАН РК
М. Ж. Журинов

Р е д а к ц и о н н а я к о л л е г и я:

Абиев Р.Ш. проф. (Россия)
Абишев М.Е. проф., член-корр. (Казахстан)
Аврамов К.В. проф. (Украина)
Апель Юрген проф. (Германия)
Баймуканов Д.А. проф., чл.-корр. (Казахстан)
Байпаков К.М. проф., академик (Казахстан)
Байтулин И.О. проф., академик (Казахстан)
Банас Иозеф проф. (Польша)
Берсимбаев Р.И. проф., академик (Казахстан)
Велихов Е.П. проф., академик РАН (Россия)
Гашимзаде Ф. проф., академик (Азербайджан)
Гончарук В.В. проф., академик (Украина)
Давлетов А.Е. проф., чл.-корр. (Казахстан)
Джрбашян Р.Т. проф., академик (Армения)
Калимолдаев М.Н. академик (Казахстан), зам. гл. ред.
Лаверов Н.П. проф., академик РАН (Россия)
Лупашку Ф. проф., чл.-корр. (Молдова)
Моход Хасан Селамат проф. (Малайзия)
Мырхалыков Ж.У. проф., академик (Казахстан)
Новак Изабелла проф. (Польша)
Огарь Н.П. проф., чл.-корр. (Казахстан)
Полещук О.Х. проф. (Россия)
Поняев А.И. проф. (Россия)
Сагиян А.С. проф., академик (Армения)
Сатубалдин С.С. проф., академик (Казахстан)
Таткеева Г.Г. проф., чл.-корр. (Казахстан)
Умбетаев И. проф., академик (Казахстан)
Хрипунов Г.С. проф. (Украина)
Юлдашбаев Ю.А. проф., член-корр. РАН (Россия)
Якубова М.М. проф., академик (Таджикистан)

«Вестник Национальной академии наук Республики Казахстан».

ISSN 2518-1467 (Online),

ISSN 1991-3494 (Print)

Собственник: РОО «Национальная академия наук Республики Казахстан» (г. Алматы)

Свидетельство о постановке на учет периодического печатного издания в Комитете информации и архивов Министерства культуры и информации Республики Казахстан №5551-Ж, выданное 01.06.2006 г.

Периодичность: 6 раз в год

Тираж: 2000 экземпляров

Адрес редакции: 050010, г. Алматы, ул. Шевченко, 28, ком. 219, 220, тел. 272-13-19, 272-13-18.

www: nauka-nanrk.kz, bulletin-science.kz

© Национальная академия наук Республики Казахстан, 2018

Адрес типографии: ИП «Аруна», г. Алматы, ул. Муратбаева, 75

E d i t o r i n c h i e f

doctor of chemistry, professor, academician of NAS RK

M. Zh. Zhurinov

E d i t o r i a l b o a r d:

Abiyev R.Sh. prof. (Russia)
Abishev M.Ye. prof., corr. member. (Kazakhstan)
Avramov K.V. prof. (Ukraine)
Appel Jurgen, prof. (Germany)
Baimukanov D.A. prof., corr. member. (Kazakhstan)
Baipakov K.M. prof., academician (Kazakhstan)
Baitullin I.O. prof., academician (Kazakhstan)
Joseph Banas, prof. (Poland)
Bersimbayev R.I. prof., academician (Kazakhstan)
Velikhov Ye.P. prof., academician of RAS (Russia)
Gashimzade F. prof., academician (Azerbaijan)
Goncharuk V.V. prof., academician (Ukraine)
Davletov A.Ye. prof., corr. member. (Kazakhstan)
Dzhrbashian R.T. prof., academician (Armenia)
Kalimoldayev M.N. prof., academician (Kazakhstan), deputy editor in chief
Laverov N.P. prof., academician of RAS (Russia)
Lupashku F. prof., corr. member. (Moldova)
Mohd Hassan Selamat, prof. (Malaysia)
Myrkhalykov Zh.U. prof., academician (Kazakhstan)
Nowak Isabella, prof. (Poland)
Ogar N.P. prof., corr. member. (Kazakhstan)
Poleshchuk O.Kh. prof. (Russia)
Ponyaev A.I. prof. (Russia)
Sagiyani A.S. prof., academician (Armenia)
Satubaldin S.S. prof., academician (Kazakhstan)
Tatkeyeva G.G. prof., corr. member. (Kazakhstan)
Umbetayev I. prof., academician (Kazakhstan)
Khripunov G.S. prof. (Ukraine)
Yuldashbayev Y.A., prof. corresponding member of RAS (Russia)
Yakubova M.M. prof., academician (Tadjikistan)

Bulletin of the National Academy of Sciences of the Republic of Kazakhstan.

ISSN 2518-1467 (Online),

ISSN 1991-3494 (Print)

Owner: RPA "National Academy of Sciences of the Republic of Kazakhstan" (Almaty)

The certificate of registration of a periodic printed publication in the Committee of Information and Archives of the Ministry of Culture and Information of the Republic of Kazakhstan N 5551-Ж, issued 01.06.2006

Periodicity: 6 times a year

Circulation: 2000 copies

Editorial address: 28, Shevchenko str., of. 219, 220, Almaty, 050010, tel. 272-13-19, 272-13-18,
<http://nauka-nanrk.kz/>, <http://bulletin-science.kz>

© National Academy of Sciences of the Republic of Kazakhstan, 2018

Address of printing house: ST "Aruna", 75, Muratbayev str, Almaty

A. A. Genbach¹, K. K. Shokolakov²¹Doctor of technical sciences, professor of «Almaty university power engineering and telecommunication»,
Almaty, Kazakhstan,²Doctoral student AUPET, design engineer JSC «Kazakh institute oil and gas», Almaty, Kazakhstan.
E-mail: kudash@bk.ru**DEVELOPMENT OF AN EXPERIMENTAL PLANT OF A NON-NOZZLE
POROUS FOAM GENERATOR FOR PRODUCING OF AIR (STEAM)
AND MECHANICAL FOAM**

Abstract. On the basis of studies of heat-mass exchange processes by boiling of pure liquids and with the addition of surface-active agents, a new class of non-nozzle porous foam generator for producing of air (steam) and mechanical foam was developed. The results of the experiment are generalized by the criteria equations of heat-mass exchange with an accuracy of $\pm 20\%$ with respect to the processes of bubbling, foam generation, pseudo-fluidization and boiling. The combined action of capillary and mass forces for capillary-porous structures of the 3x0,4 type made it possible to boost the operating mode of the foam generator by 1,5-2 times and reduce the consumption of the foam generating agent and reduce the hydraulic resistance tenfold.

Key words: porous foam generator, foam generation, heat-mass exchange, capillary-porous structures.

Study of the heat and mass exchange of boiling pure liquids in capillary porous structures, development of control methods for these processes [1] allowed to summarize trials with pure foam and dust-foam flows and study a single equation for calculation of the heat and mass exchange with an accuracy up to $\pm 20\%$ [2], whereby boiling processes, bubbling, pseudo-fluidization and foam generation were summarized as well.

A new class of nozzle-free foam generators and foam-dust catchers along with bubbling capillary porous grids were invented [3], as well as foam generating and defoaming structures located vertically. Due to the controlling internal characteristics of two-phase flows [4] different types of foam-dust catchers were designed [5-13]. It is possible to increase effectiveness of dust-gas catching because of controlling geometry of micro channels of porous material [6], separation of flow into wave energy and gas (steam) energy [7,11], forming generator with the help of power (without incoming flotation) [8], design of turbulizers as foam generating and defoaming structures using a joint action of gravitation and capillary forces, pressure and vibration forces.

In accordance with the article No.358012, 1972 a method of electrostatic gas cleanup was described where electrization of settling elements was produced using a tribo effect. This effect was used earlier, though during electrization of filter elements they had a conductive layer on their surface, which reduced the electrostatic filtration component. The reviewed method describes that an effectiveness of electrostatic filters will be increased because it is recommended to implement electrization with the help of circulation of weight fine grained electrified agent in hollow settling elements.

Method of electrostatic gas cleanup as per the article No.358012, 1972 in terms of dust settling effectiveness exceeds the known methods. However, in comparison with the known methods it has a low dust settling productivity.

Therefore, it is possible to increase effectiveness of dust electrization in air flow by using a tribo effect. Though it requires to solve a problem of dust cleanup productivity.

In addition to methods of gas cleanup from dust there is a method /article No. 247241, 1969/, where it is suggested to catch thin aerosol sprays with the help of charging aerosol spray particles when the electrostatics spray easily evaporating liquids are settled on them, hence a liquid vapor in a form of condensate will be re-used. Such method has an advantage over method of dust catching by charging electrostatic sprayed water, because a mutual attraction of dust particles and drops of sprayed water leads to their adhesion, and growth of particles along with charge neutralization.

A common disadvantage of electric methods is a minor size and porous structure of formed aggregation of dust particles. Under impact they can be easily destroyed. Low effectiveness of dust suppression process could be expected from settling of fine dust. Thus, it is required to develop a dust suppression method, which would allow significantly increase resistance to destruction of formed dust aggregation whilst processing an air dust flow by electric field with retention of high productivity of dust cleanup.

It is interesting to see the air dedusting method using porous blankets /article No. №368413, 1973/. In order to increase an effectiveness of dust catching a dust flow goes through the parallel blankets that moist liquid. A moving air flow helps to vibrate blankets due to the irregular speeds. Dust particles located in air turbulent flow are being moisturized and coagulated. Fiber is moisturized by water supply to pipe frame where the blankets are fixed.

To achieve a required effectiveness of dust catching it is necessary to conduct multiple test researches in various mode parameters, as well as perform new design studies for forming an aerodynamic structure of air dust flow.

There is a dust suppression method based on enriched water steam. With steam condensate the area of low pressure is formed where all particles move and could be caught. The disadvantage of such method is its low effectiveness that is caused by unreasonable use of generated steam for the purposes of dust suppression. Besides, to achieve a required norm of dust content large steam resources are required, and that result in unreasonable costs for steam generation.

Similar method to the above-mentioned method is a method (article No. 130461), where air dust flow is mixed with steam spray with further settling of steam-dust flow by the sprayed water.

Under such process it is expected to obtain a low degree of dust catching. Condensate effect will be shown in unstable way, takes probabilistic nature depending on random contact of water sprayed drops with water steam molecules and will be determined by turbulence degree of air dust flow. Dust coagulation effectiveness is expected as minor in conditions of enriching air dust flow by steam. That is why water steam and sprayed water are used unreasonably, and there is increased consumption of steam and water.

When studying a movement of aerosol particles in the steam diffusion field it was evident that the aerosol particles are intensively remote from a cold surface. Aerosols with speed 1 m/s were put through the condenser of 0,5 m long and 5×10^{-3} m wide. Metal wall is washed by water with temperature at condenser inlet 20°C and outlet about minus 70°C . Particle concentration was 1012 particles/ m^3 . Catching degree varied in large limits 75-95%. Mechanism of the dust suppression process is based on two principles: 1)

condensate enlargement of aerosol particles like condensation nucleus; 2) directed movement of steam particles mainly towards a cold surface.

Mechanism of the dust suppression process is very complicated, though the main acting factors could be indicated such as Stefan flow of condensed steam as a driving force of aerosol particles. Also it is enforced by the available diffusion, thermophoretic forces and convective flows, large particles are removed from flow due to the gravitation and centrifugal forces; some particles in air steam flow are minimized because of coagulation process.

Study of the mechanism of dust suppression in the steam diffusion field requires further development, in particular it is related to enhancement of the steam condensation process, steadiness of liquid film distribution, development of new devices for feeding air dust flow by the enriched steam.

Some enhancement of the dust suppression processes could be achieved by additional power sources /article No. 1032197, 1983/. It is suggested to charge water steam and dispersed water oppositely, whereas water should be previously magnetized. Steam is injected to a tank with hot mass, which goes through the electric field formed at the steam nozzle outlet. Steam-air-dust flow leaving a tank is condensed at sprayed drops of electrically charged and magnetized water.

Under the weight steam consumption equal to 7×10^{-3} kg/f and over, a relative air dust content reaches up to 3-6% and becomes self-simulated in relation to steam consumption. The increase of process effectiveness in the described condensate system of dust suppression occurs 1,5-2 times (probably in relation to condensate system without electric charge of steam, water and magnetization of water). Also it is unclear how it impacts upon the process of water magnetization, and what contribution of electric charge separately for steam and water is.

There each effect is explained by the fact that when oppositely electrically charged sprays of water and steam are injected to the dust source due to electric gravity forces between steam molecules and water drops it leads to more enhanced and ordered steam condensation at water drops. At condensate surface a larger hydrodynamic flotation occurs rather than at non-charged aerosols, which directs to drops that collect dust particles and tends to their catch by drops. Due to that a mass of dust particles are settled. Capture rate of dust particles by water drops also is increased due to minimizing forces of surface tension of electrically charged drops.

The described method of dust suppression has an additional effect on settling dust particles. However, it is achieved by huge efforts as it requires the electric charge of steam, water, water magnetization that significantly complicates a condensate system of dust suppression, and extra costs for establishing electric fields and ensuring electrical safety of manpower.

Therefore, further theoretical and experimental studies of the dust suppression processes should be aimed at new design solutions that are based on the reviewed methods using evaporator-condensing multiphase systems of dust collection and surface-active agents.

Basically, in terms of the existing types of foam generating agents we could hope for the new aerodynamic diagrams and structures, which will determine a behavior of dust suppression process, significantly increasing a cleanup degree of dust flow, and become reliable and easy to fabricate and operate and meet safety requirements whilst operating the equipment [8-13].

Figure 1 demonstrates a new class of nozzle-free foam generator with foam generating capillary porous structure.

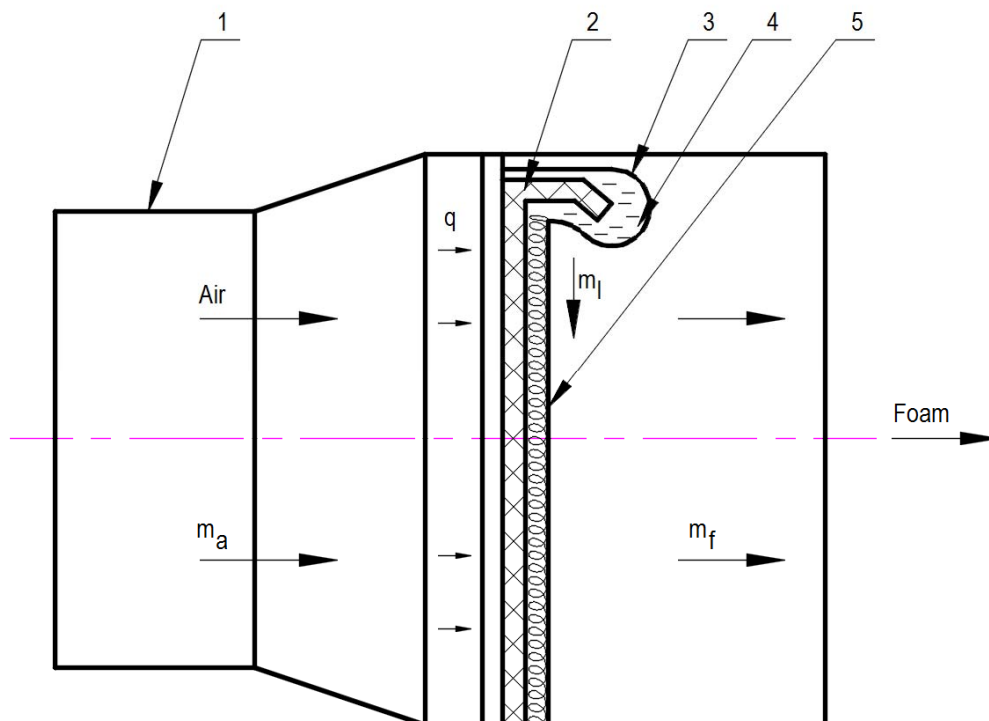

Figure 1 – Nozzle-free capillary porous foam generator of air (steam) mechanical foam:

1 – cylindrical case; 2 – capillary porous structure; 3 – spray device (feeding artery); 4 – foam generating solution; 5 – air (steam) – mechanical foam; m_a, m_l, m_s – consumption of air (steam), liquid (foam generating solution), foam; q – incoming (foam generating) flow energy density.

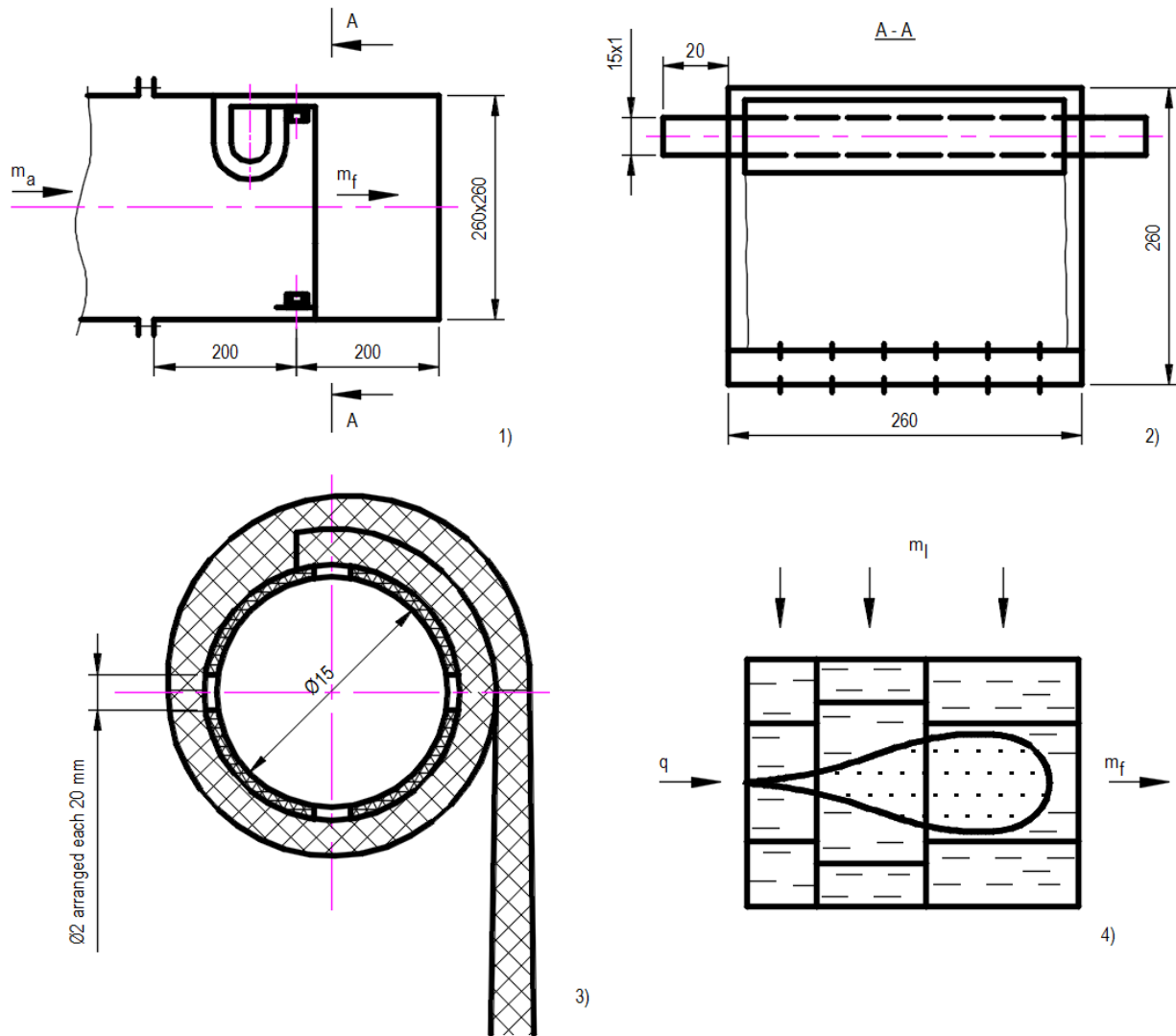

Figure 2 – Test facility for research of foam generation process:
 1 – Foam generator; 2 – spray device; 3 – connection of capillary porous structure; 4 – bubble dynamics in structure

Figure 2 demonstrates a test facility for research of air (steam) generation processes - mechanical foam. Combined use of mass and capillary forces ensures formation of uniform and stable film for distribution of the foam generation solution throughout all capillary porous structure $3 \times 0,4$ (three layers of grid where cell width in light is $0,4 \cdot 10^{-3}$ m). This allows to increase operational mode of foam generator up to 1,5-2 times, reduce consumption of foam forming agent whilst retaining foam stability, dispersion and high expansion rate. Value of hydraulic resistance will be a few times less because of nozzle unavailability rather than in foam generators GVPV-400 or PGG-4.

REFERENCES

- [1] Polyayev V.M., Genbach A.A. Upravleniye teploobmenom v poristih strukturah // Izvestiya Rossiiskoi akademii nauk. «Energetikai transport». 1992. Vol. 38, N 6/ P. 105-110.
- [2] Polyayev V.M., Genbach A.A. Teploobmen v poristoisisteme, rabota shiiprisovmestnom deistviikapillyarnih gravitacionnihsil // Teploenergetika. 1193. N 7. P. 55-58.
- [3] Genbach A.A., Kulbakina N.V. Pilepodavleniye i pileulavlivanie s pomoshchyu cirkulacionnogo openogeneratora s poristostrukturou // Energetikai toplivniy resursi Kazakhstana. 2010. N 4. P. 62-65.
- [4] Polyayev V.M., Genbach A.A. Upravleniye vnutrennimi harakteristikami kipeniya v poristoisisteme // Kriogennaya tekhnika i kondicionirovaniye: sbornik trudov MGTU. 1991. P. 224-237.
- [5] Polyayev V.M., Genbach A.A. Primeneniye poristoisistemi v energeticheskikh ustanovkakh // Promishlennaya energetika. 1192. N 1. P. 40-43.

- [6] Genbach A.A., Piontskovskii M.S. Poristiipilegazoulovitel s upravlyaemoigeometrieimikrokanalov // Energetikaitoplivnieresursi Kazahstana. 2010. N 4. P. 59-61.
- [7] Polyayev V.M., Genbach A.A., Minashkin D.V. Processi v poristomellipticheskometploobmennike // Izvestiyavuzov. Mashinostroenie. 1991. N 4-6. P. 73-77.
- [8] Genbach A.A., Genbach N.A. Issledovaniepenogeneratorsa obogrevaemoipoverhnostu // Vestnik AIES. Almaty, 2009. N 4. P. 24-27.
- [9] Genbach A.A., Genbach N.A. Issledovaniyekapillyarno-poristihsystem v teplovihenergeticheskikhustanovkahelektrostancii // Vestnik AIES. Almaty, 2011. N 2(13). P. 57-62.
- [10] Genbach A.A., Genbach N.A. Primeneniyekapillyarno-poristihsystem v teplovihenergeticheskikhustanovkahelektrostancii // Vestnik AIES. Almaty, 2011. N 3(14). P. 4-11.
- [11] Polyayev V.M., Genbach A.N., Genbach A.A. Methods of Monitoring Energy Processes // Experimental thermal and fluid science, International of Thermodynamics, Experimental Heat Transfer, and Fluid Mechanics. Avenue of the Americas. New York, 1995. Vol. 10. P. 273-286.
- [12] Genbach A.A., Shokolakov K. Poristiipenniipileulovitel. MON RK, Mezhdynarodniinauchniizhurnal – prilozhenieRespubliki Kazahstan – Poisk. 2011. N 2. P. 266-271.
- [13] Polyayev V.M., Genbach A.A. Plotnostcentrovaroobrazovaniyaivibroskapelizporistoistrukturi // Izvestiya vuzov. Mashinostroenie. 1990. N 9. P. 50-55.

А. А. Генбач¹, К. К. Шоколаков²

¹Алматы энергетика және байланыс университеті, Алматы, Қазақстан,

²«Қазақ Мұнай және Газ Институты» АҚ, Алматы, Қазақстан

АУА (БУ) – МЕХАНИКАЛЫҚ КӨПІРІКТІҢ БҮРІККІШСІЗ БОРҚЫЛДАҚ КӨПІРІК ГЕНЕРАТОРЫН ЭКСПЕРИМЕНТАЛДЫ ОРНАТУДЫ ӘЗІРЛЕУ

Аннотация. Таза сұйықтықтарды қайнатумен және қабатты-белсенді заттарды қосумен жылу-салмақ алмастырғыш үдерісті зерттеу негізінде ауа (бу) – механикалық көпірлікті бүріккішсіз капиллярлы-борқылдақ көпірлік генераторларының жаңа класы әзірленді. Эксперимент нәтижелерін жылыну мен масса тасымалының критикалық теңдеулеріне көбік, поролон жасау, псевдоожолдау және қайнау процестеріне қатысты $\pm 20\%$ дәлдікпен қорытылады. Капиллярлы-бұрқылдақ құрылымдар үшін $3 \times 0,4$ түріндегі капиллярлы және салмақты бірыңғай әрекеттер көпірлік генераторының жұмыс режимін 1,5-2 есе тездетуге, көпірлік қалыптастырушының шығындарын қысқартуға және гидравликалық қақтығысты он есе азайтуға мүмкіндік берді.

Түйін сөздер: борқылдақ көпірлік генераторы, көпірлік генерациясы, жылу салмақ алмастырғыш, капиллярлы-борқылдақ құрылымдар.

А. А. Генбач¹, К. К. Шоколаков²

¹Доктор технических наук, профессор, кафедра «Тепловые энергетические установки»,

Алматинский университет энергетики и связи, Алматы, Казахстан,

²докторант Алматинского университета энергетики и связи, специальность «Теплоэнергетика», кафедра «Тепловые энергетические установки», инженер-проектировщик АО «Казахский институт нефти и газа», Алматы, Казахстан

РАЗРАБОТКА ЭКСПЕРИМЕНТАЛЬНОЙ УСТАНОВКИ БЕЗФОРСУНОЧНОГО ПОРИСТОГО ПЕНОГЕНЕРАТОРА ВОЗДУШНО (ПАРО) – МЕХАНИЧЕСКОЙ ПЕНЫ

Аннотация. На основе исследований процессов тепло-массообмена кипением чистых, жидкостей и с добавкой поверхностно-активных веществ разработан новый класс безфорсуночных капиллярно-пористых пеногенераторов воздушно (паро) – механической пены. Результаты эксперимента обобщаются критерисными уравнениями тепло- и массообмена с точностью $\pm 20\%$ применительно к процессам барботажа, пеногенерации, псевдоожожения и кипения. Совместное действие капиллярных и массовых сил для капиллярно-пористых структур вида $3 \times 0,4$ позволило форсировать в 1,5-2 раза режим работы пеногенератора, сократить расход пенообразователя и в десятки раз уменьшить гидравлическое сопротивление.

Ключевые слова: пористый пеногенератор, пеногенерация, тепломассообмен, капиллярно-пористые структуры.

Publication Ethics and Publication Malpractice in the journals of the National Academy of Sciences of the Republic of Kazakhstan

For information on Ethics in publishing and Ethical guidelines for journal publication see <http://www.elsevier.com/publishingethics> and <http://www.elsevier.com/journal-authors/ethics>.

Submission of an article to the National Academy of Sciences of the Republic of Kazakhstan implies that the described work has not been published previously (except in the form of an abstract or as part of a published lecture or academic thesis or as an electronic preprint, see <http://www.elsevier.com/postingpolicy>), that it is not under consideration for publication elsewhere, that its publication is approved by all authors and tacitly or explicitly by the responsible authorities where the work was carried out, and that, if accepted, it will not be published elsewhere in the same form, in English or in any other language, including electronically without the written consent of the copyright-holder. In particular, translations into English of papers already published in another language are not accepted.

No other forms of scientific misconduct are allowed, such as plagiarism, falsification, fraudulent data, incorrect interpretation of other works, incorrect citations, etc. The National Academy of Sciences of the Republic of Kazakhstan follows the Code of Conduct of the Committee on Publication Ethics (COPE), and follows the COPE Flowcharts for Resolving Cases of Suspected Misconduct (http://publicationethics.org/files/u2/New_Code.pdf). To verify originality, your article may be checked by the Cross Check originality detection service <http://www.elsevier.com/editors/plagdetect>.

The authors are obliged to participate in peer review process and be ready to provide corrections, clarifications, retractions and apologies when needed. All authors of a paper should have significantly contributed to the research.

The reviewers should provide objective judgments and should point out relevant published works which are not yet cited. Reviewed articles should be treated confidentially. The reviewers will be chosen in such a way that there is no conflict of interests with respect to the research, the authors and/or the research funders.

The editors have complete responsibility and authority to reject or accept a paper, and they will only accept a paper when reasonably certain. They will preserve anonymity of reviewers and promote publication of corrections, clarifications, retractions and apologies when needed. The acceptance of a paper automatically implies the copyright transfer to the National Academy of Sciences of the Republic of Kazakhstan.

The Editorial Board of the National Academy of Sciences of the Republic of Kazakhstan will monitor and safeguard publishing ethics.

Правила оформления статьи для публикации в журнале смотреть на сайте:

www.nauka-nanrk.kz

ISSN 2518-1467 (Online), ISSN 1991-3494 (Print)

<http://www.bulletin-science.kz/index.php/ru/>

Редакторы *М. С. Ахметова, Т. М. Апендиев, Д. С. Аленов*
Верстка на компьютере *Д. Н. Калкабековой*

Подписано в печать 16.02.2018.

Формат 60x881/8. Бумага офсетная. Печать – ризограф.

14,2 п.л. Тираж 2000. Заказ 1.