

ISSN 2518-1467 (Online),
ISSN 1991-3494 (Print)

ҚАЗАҚСТАН РЕСПУБЛИКАСЫ
ҰЛТТЫҚ ҒЫЛЫМ АКАДЕМИЯСЫНЫҢ

Х А Б А Р Ш Ы С Ы

ВЕСТНИК

НАЦИОНАЛЬНОЙ АКАДЕМИИ НАУК
РЕСПУБЛИКИ КАЗАХСТАН

THE BULLETIN

OF THE NATIONAL ACADEMY OF SCIENCES
OF THE REPUBLIC OF KAZAKHSTAN

1944 ЖЫЛДАН ШЫҒА БАСТАҒАН
ИЗДАЕТСЯ С 1944 ГОДА
PUBLISHED SINCE 1944

6

АЛМАТЫ
АЛМАТЫ
ALMATY

2018

ҚАРАША
НОЯБРЬ
NOVEMBER

NAS RK is pleased to announce that Bulletin of NAS RK scientific journal has been accepted for indexing in the Emerging Sources Citation Index, a new edition of Web of Science. Content in this index is under consideration by Clarivate Analytics to be accepted in the Science Citation Index Expanded, the Social Sciences Citation Index, and the Arts & Humanities Citation Index. The quality and depth of content Web of Science offers to researchers, authors, publishers, and institutions sets it apart from other research databases. The inclusion of Bulletin of NAS RK in the Emerging Sources Citation Index demonstrates our dedication to providing the most relevant and influential multidiscipline content to our community.

Қазақстан Республикасы Ұлттық ғылым академиясы "ҚР ҰҒА Хабаршысы" ғылыми журналының Web of Science-тің жаңаланған нұсқасы Emerging Sources Citation Index-те индекстелуге қабылданғанын хабарлайды. Бұл индекстелу барысында Clarivate Analytics компаниясы журналды одан әрі the Science Citation Index Expanded, the Social Sciences Citation Index және the Arts & Humanities Citation Index-ке қабылдау мәселесін қарастыруда. Web of Science зерттеушілер, авторлар, баспашылар мен мекемелерге контент тереңдігі мен сапасын ұсынады. ҚР ҰҒА Хабаршысының Emerging Sources Citation Index-ке енуі біздің қоғамдастық үшін ең өзекті және беделді мультидисциплинарлы контентке адалдығымызды білдіреді.

НАН РК сообщает, что научный журнал «Вестник НАН РК» был принят для индексирования в Emerging Sources Citation Index, обновленной версии Web of Science. Содержание в этом индексировании находится в стадии рассмотрения компанией Clarivate Analytics для дальнейшего принятия журнала в the Science Citation Index Expanded, the Social Sciences Citation Index и the Arts & Humanities Citation Index. Web of Science предлагает качество и глубину контента для исследователей, авторов, издателей и учреждений. Включение Вестника НАН РК в Emerging Sources Citation Index демонстрирует нашу приверженность к наиболее актуальному и влиятельному мультидисциплинарному контенту для нашего сообщества.

Б а с р е д а к т о р ы

х. ғ. д., проф., ҚР ҰҒА академигі

М. Ж. Жұрынов

Р е д а к ц и я а л қ а с ы:

Абиев Р.Ш. проф. (Ресей)
Абишев М.Е. проф., корр.-мүшесі (Қазақстан)
Аврамов К.В. проф. (Украина)
Аппель Юрген проф. (Германия)
Баймуқанов Д.А. проф., корр.-мүшесі (Қазақстан)
Байпақов К.М. проф., академик (Қазақстан)
Байтулин И.О. проф., академик (Қазақстан)
Банас Иозеф проф. (Польша)
Берсимбаев Р.И. проф., академик (Қазақстан)
Велихов Е.П. проф., РҒА академигі (Ресей)
Гашимзаде Ф. проф., академик (Әзірбайжан)
Гончарук В.В. проф., академик (Украина)
Давлетов А.Е. проф., корр.-мүшесі (Қазақстан)
Джрбашян Р.Т. проф., академик (Армения)
Қалимолдаев М.Н. проф., академик (Қазақстан), бас ред. орынбасары
Лаверов Н.П. проф., академик РАН (Россия)
Лупашку Ф. проф., корр.-мүшесі (Молдова)
Мохд Хасан Селамат проф. (Малайзия)
Мырхалықов Ж.У. проф., академик (Қазақстан)
Новак Изабелла проф. (Польша)
Огарь Н.П. проф., корр.-мүшесі (Қазақстан)
Полещук О.Х. проф. (Ресей)
Поняев А.И. проф. (Ресей)
Сагиян А.С. проф., академик (Армения)
Сатубалдин С.С. проф., академик (Қазақстан)
Таткеева Г.Г. проф., корр.-мүшесі (Қазақстан)
Умбетаев И. проф., академик (Қазақстан)
Хрипунов Г.С. проф. (Украина)
Юлдашбаев Ю.А. проф., РҒА корр.-мүшесі (Ресей)
Якубова М.М. проф., академик (Тәжікстан)

«Қазақстан Республикасы Ұлттық ғылым академиясының Хабаршысы».

ISSN 2518-1467 (Online),

ISSN 1991-3494 (Print)

Меншіктенуші: «Қазақстан Республикасының Ұлттық ғылым академиясы»РҚБ (Алматы қ.)

Қазақстан республикасының Мәдениет пен ақпарат министрлігінің Ақпарат және мұрағат комитетінде
01.06.2006 ж. берілген №5551-Ж мерзімдік басылым тіркеуіне қойылу туралы куәлік

Мерзімділігі: жылына 6 рет.

Тиражы: 2000 дана.

Редакцияның мекенжайы: 050010, Алматы қ., Шевченко көш., 28, 219 бөл., 220, тел.: 272-13-19, 272-13-18,
www: nauka-nanrk.kz, bulletin-science.kz

© Қазақстан Республикасының Ұлттық ғылым академиясы, 2018

Типографияның мекенжайы: «Аруна» ЖК, Алматы қ., Муратбаева көш., 75.

Г л а в н ы й р е д а к т о р
д. х. н., проф. академик НАН РК
М. Ж. Журинов

Р е д а к ц и о н н а я к о л л е г и я:

Абиев Р.Ш. проф. (Россия)
Абишев М.Е. проф., член-корр. (Казахстан)
Аврамов К.В. проф. (Украина)
Апель Юрген проф. (Германия)
Баймуканов Д.А. проф., чл.-корр. (Казахстан)
Байпаков К.М. проф., академик (Казахстан)
Байтулин И.О. проф., академик (Казахстан)
Банас Иозеф проф. (Польша)
Берсимбаев Р.И. проф., академик (Казахстан)
Велихов Е.П. проф., академик РАН (Россия)
Гашимзаде Ф. проф., академик (Азербайджан)
Гончарук В.В. проф., академик (Украина)
Давлетов А.Е. проф., чл.-корр. (Казахстан)
Джрбашян Р.Т. проф., академик (Армения)
Калимолдаев М.Н. академик (Казахстан), зам. гл. ред.
Лаверов Н.П. проф., академик РАН (Россия)
Лупашку Ф. проф., чл.-корр. (Молдова)
Мохд Хасан Селамат проф. (Малайзия)
Мырхалыков Ж.У. проф., академик (Казахстан)
Новак Изабелла проф. (Польша)
Огарь Н.П. проф., чл.-корр. (Казахстан)
Полещук О.Х. проф. (Россия)
Поняев А.И. проф. (Россия)
Сагиян А.С. проф., академик (Армения)
Сатубалдин С.С. проф., академик (Казахстан)
Таткеева Г.Г. проф., чл.-корр. (Казахстан)
Умбетаев И. проф., академик (Казахстан)
Хрипунов Г.С. проф. (Украина)
Юлдашбаев Ю.А. проф., член-корр. РАН (Россия)
Якубова М.М. проф., академик (Таджикистан)

«Вестник Национальной академии наук Республики Казахстан».

ISSN 2518-1467 (Online),

ISSN 1991-3494 (Print)

Собственник: РОО «Национальная академия наук Республики Казахстан» (г. Алматы)

Свидетельство о постановке на учет периодического печатного издания в Комитете информации и архивов Министерства культуры и информации Республики Казахстан №5551-Ж, выданное 01.06.2006 г.

Периодичность: 6 раз в год

Тираж: 2000 экземпляров

Адрес редакции: 050010, г. Алматы, ул. Шевченко, 28, ком. 219, 220, тел. 272-13-19, 272-13-18.

www: nauka-nanrk.kz, bulletin-science.kz

© Национальная академия наук Республики Казахстан, 2018

Адрес типографии: ИП «Аруна», г. Алматы, ул. Муратбаева, 75

E d i t o r i n c h i e f

doctor of chemistry, professor, academician of NAS RK

M. Zh. Zhurinov

E d i t o r i a l b o a r d:

Abiyev R.Sh. prof. (Russia)
Abishev M.Ye. prof., corr. member. (Kazakhstan)
Avramov K.V. prof. (Ukraine)
Appel Jurgen, prof. (Germany)
Baimukanov D.A. prof., corr. member. (Kazakhstan)
Baipakov K.M. prof., academician (Kazakhstan)
Baitullin I.O. prof., academician (Kazakhstan)
Joseph Banas, prof. (Poland)
Bersimbayev R.I. prof., academician (Kazakhstan)
Velikhov Ye.P. prof., academician of RAS (Russia)
Gashimzade F. prof., academician (Azerbaijan)
Goncharuk V.V. prof., academician (Ukraine)
Davletov A.Ye. prof., corr. member. (Kazakhstan)
Dzhrbashian R.T. prof., academician (Armenia)
Kalimoldayev M.N. prof., academician (Kazakhstan), deputy editor in chief
Laverov N.P. prof., academician of RAS (Russia)
Lupashku F. prof., corr. member. (Moldova)
Mohd Hassan Selamat, prof. (Malaysia)
Myrkhalykov Zh.U. prof., academician (Kazakhstan)
Nowak Isabella, prof. (Poland)
Ogar N.P. prof., corr. member. (Kazakhstan)
Poleshchuk O.Kh. prof. (Russia)
Ponyaev A.I. prof. (Russia)
Sagiyani A.S. prof., academician (Armenia)
Satubaldin S.S. prof., academician (Kazakhstan)
Tatkeyeva G.G. prof., corr. member. (Kazakhstan)
Umbetayev I. prof., academician (Kazakhstan)
Khripunov G.S. prof. (Ukraine)
Yuldashbayev Y.A., prof. corresponding member of RAS (Russia)
Yakubova M.M. prof., academician (Tadjikistan)

Bulletin of the National Academy of Sciences of the Republic of Kazakhstan.

ISSN 2518-1467 (Online),

ISSN 1991-3494 (Print)

Owner: RPA "National Academy of Sciences of the Republic of Kazakhstan" (Almaty)

The certificate of registration of a periodic printed publication in the Committee of Information and Archives of the Ministry of Culture and Information of the Republic of Kazakhstan N 5551-Ж, issued 01.06.2006

Periodicity: 6 times a year

Circulation: 2000 copies

Editorial address: 28, Shevchenko str., of. 219, 220, Almaty, 050010, tel. 272-13-19, 272-13-18,
<http://nauka-nanrk.kz/>, <http://bulletin-science.kz>

© National Academy of Sciences of the Republic of Kazakhstan, 2018

Address of printing house: ST "Aruna", 75, Muratbayev str, Almaty

S.A. Keshuov¹, Sh. Shokolakova¹, A.A. Saukhimov², E. Shuvalova³

¹Kazakh national agricultural university, Almaty, Kazakhstan,

²Almaty University of Power Engineering and Telecommunications, Almaty, Kazakhstan,

³Tallinn University of Technology, Tallinn, Estonia.

E-mail: shinara.shokolakova@mail.ru

RESEARCH OF VOLTAGE DEVIATION IN RURAL ELECTRICAL GRID WITH DISTRIBUTED GENERATION

Abstract. In accordance with the strategy for the development of energy in Kazakhstan in agriculture, it is necessary to solve the important problem of reducing the energy intensity of agricultural production [1, 2]. The key difficulties in integrating high-capacity generation of renewable energy sources (RES) into the grid are the planning and management of the system. Scenarios for studying the impact on the system depend on high or low load, high proportion or absence of wind/solar energy. For each case, the bus voltage is calculated and checked for compliance with permissible limits, the calculation of the flow distribution of active and reactive power, as well as losses in the transformer, on power lines, generators and other components. Most wind and solar power plants do not provide inertial response or control of statism [3]. A number of difficulties arise related to the stability of the voltage in transient modes. In this regard, the actual issue is the introduction of adaptive controllers for controlling inverters, depending on the change in the mode parameters [4, 5]. In this paper, we present the results of studies on the modeling of transient regimes using the example of the SPP with an installed capacity of 2 MW describes the possibility of changing the principles of system management, which is the most economical solution to the problems of integrating wind and photovoltaic solar energy into a network. The virtual model of the PSCad analyzed the stability of the voltage in the event of a short circuit on the 10 kV bus, algorithms and mechanisms for using the intelligent controller for controlling the photovoltaic system were developed.

Keywords: distributed generation, integration of solar power plants, voltage deviation, transient modes, short-circuit current.

Introduction. The current state policy on the introduction of green and clean technologies encourages the construction of renewable energy sources, such as wind farms, solar power plants (SPP) and small hydropower plants. According to the data presented in [6, 7], by the end of 2025, it is expected to connect more than 3,000 MW of RES or 15% of the total installed capacity of the generating stations of the Republic. Including, the share of SPP will be 650 MW. With the increase in the share of RES in the total balance of capacity, electromagnetic processes in systems with power converters have a significant effect on voltage stabilization. It is known that the occurrence of a short circuit (SC) due to an unstable damage inevitably leads to a voltage drop in one or several phases (possibly also to a voltage jump in undamaged phases), depending on the type and location of the fault. For this reason, the grid rules of countries with developed renewable energy require that the connection of a high-power RES-power system keep the voltage drop in the network to a certain level (usually in percentage of the nominal voltage) without switching off.

Since 2015, the system operator of KEGOC JSC for the reconciliation of the scheme for issuing the power of renewable energy has introduced "System operator requirements for ensuring integration of RES with the energy system" [8, 9], where one of the main requirements is to ensure the stability of RES voltage in transient modes. The document contains the conditions for RES operation when the linear (phase-to-phase) voltage falls at the point of connection to the network caused by the asynchronous mode in the adjacent network or by close short circuits (symmetrical or asymmetric) [9]. The required voltage value is provided by generating a controlled volume of reactive power. Figure 1 shows the "voltage-time" characteristic at the time of the accident.

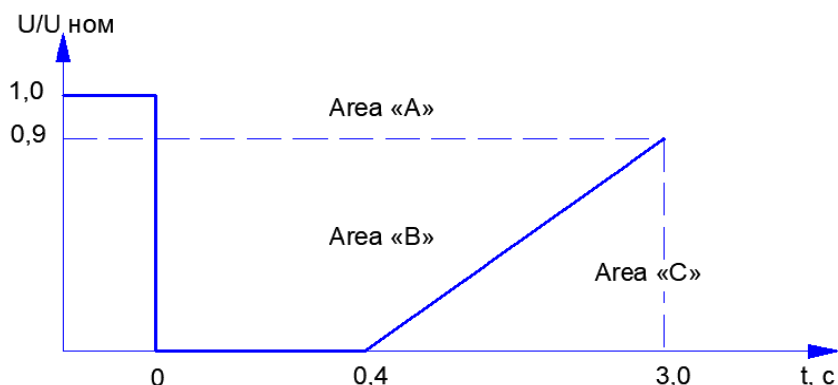

Figure 1 – Diagram of restrictions of switching off generating plants from the common network in the parameters of level-duration of voltage drop

Area "A" - RES must remain connected to the network and function steadily;

Area "B" - RES must remain connected to the network and provide maximum voltage support by generating a controlled volume of reactive power;

Area "C" - it is allowed to disconnect RES from the network.

Thus, it is required that the RES object in case of voltage drop to 0 in the time interval between 0.4s and 3s remains connected to the power system (zone B) or be disconnected (zone C) from the external network as the voltage deviation U/U_{nom} changes curve on figure 1.

For solar power plants, provision of permissible voltage is possible due to adaptive regulation of the inverter's operation, the task of which is to receive the reactive component from the network to stabilize the voltage when increasing and to generate reactive power with an unacceptable voltage drop. The change in the value of $\cos(\varphi)$ should be within 0.85 ind and 0.85 cap [10]. The results of the studies presented in [3-5, 10, 11] show that providing a voltage within a given range is one of the most difficult tasks, the solution of which depends on changing climatic conditions (humidity, wind, solar radiation, etc.) temperature heating of cells, as well as the number of solar panels at the station, affecting the fluctuations in output power. For SES connected to an external electrical network (on-line), the provision of permissible voltage levels in normal and post-emergency modes is possible at the expense of power storage devices, but the cost of such installations is not yet sufficiently acceptable for companies [10].

In this regard, an effective means of voltage regulation is the use of an intelligent regulator for controlling the photovoltaic power supply system [4]. However, the use of this approach requires the development of adaptive algorithms that will in real time regulate the conversion of active and reactive current in inverters depending on the voltage level on the bus bars of the connected external network.

In this article, studies have been conducted to maintain the voltage inverters of the 2-MW SPP like as in Kapshagai city in the south of Kazakhstan in the event of a short-circuit occurring in the PScad™ software package. PScad is a high-speed, accurate to 0.001s. and a simple tool for modeling the operation of power systems and power electronic converters in their design, analysis, optimization and verification. and also proposed algorithms and mechanisms for ensuring stable operation of the power system in transient regimes.

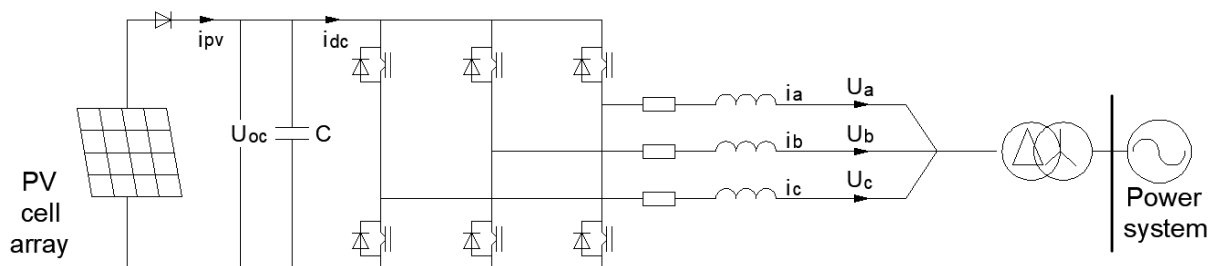

This SPP is connected to an external 10 kV network via a 0.4/10 kV step-up transformer. The voltage variation in the transient regimes was estimated under the conditions of the occurrence of a 3-phase short circuit (short circuit) on the 10 kV busbars of a 1-second transformer substation. Modeling is performed in the PScad™ software package. The PScad program with the EMTDC™ transient simulation module provides a wide range of tools and a large component library for detailed analysis of the operation of power equipment. The result of the system simulation are graphs of the transients of currents and voltages at the input and output of the system for both ac networks and for the DC transmission system. The line parameters are given in the form of lumped inductances, capacitance and resistances, equivalent to the physical parameters of the line.

Results and discussion. To model the SPP, the structural diagram of which is shown in figure 2, we write the output voltage at the solar power plant in a matrix form for 3 phases (2):

$$\begin{bmatrix} U_{sa} \\ U_{sb} \\ U_{sc} \end{bmatrix} = (R + L \frac{d}{dt}) \begin{bmatrix} i_a \\ i_b \\ i_c \end{bmatrix} + \begin{bmatrix} u_a \\ u_b \\ u_c \end{bmatrix} \quad (1)$$

where U_{sa} , U_{sb} , U_{sc} is the voltage of the inverter, i_a , i_b , i_c is the inverter current, u_a , u_b , u_c is the voltage of the external electrical network.

In accordance with the requirements of transmitting electrical networks [9], it is necessary that at the time of transient regimes the accident does not spread to distribution networks and does not provoke its cascade development.

Voltage stability in PV systems is determined by the operation of inverters, which must regulate the generation of active and reactive power during short-circuit or other transient processes [11]. The mathematical model of the inverter operation is described by the following equations (3, 4) in the simplified coordinate system d, q:

$$u_{sd} = Ri_d + L \frac{di_d(t)}{dt} - \omega Li_q + u_d \quad (2)$$

$$u_{sq} = Ri_q + L \frac{di_q(t)}{dt} + \omega Li_d - u_q$$

$$\begin{aligned} P &= u_d i_d + u_q i_q \\ Q &= u_q i_q - u_d i_d \end{aligned} \quad (3)$$

From figure 3A, we can observe that after a 3-phase short circuit on a 10kV bus, the inverter goes into protection mode and automatically removes the voltage at the output, the instantaneous and active voltage on the 10kV buses is reduced to 0 and restored only after the short circuit is completed. There is a decrease in the generated currents, and accordingly the active and reactive power from the SPP. For 1 second SPP does not contribute to the external power supply voltage. When the external voltage drops to a critical level, the SPP automatics takes it to isolated work in order to ensure the stable operation of the integrated electric network.

Analysis of simulation of transient modes shows that as a result of the absence of a reverse electro-mechanical connection of the power system from the SES, intelligent regulators must be used to control the output voltage, which will adaptively control the generation of active and reactive power when the external parameters of the electrical network change. Figure 4 shows the block diagram of Iq operation of the regulator for operation in the SPP system when connected to an external electrical network.

Models of automatic systems based on semiconductor converters with pulse-width modulation belong to the class of systems of the following type [8]:

$$\frac{dX}{dt} = G(A, \bar{X}, t), \quad (4)$$

where X is a vector of phase variables; G is a periodic vector function; A is the matrix of the parameters of the system.

The solution of the system (1) has the form:

$$\bar{X}(t) = \bar{X}(t + T).$$

The converter replacement circuit is described by a system of nonlinear differential equations

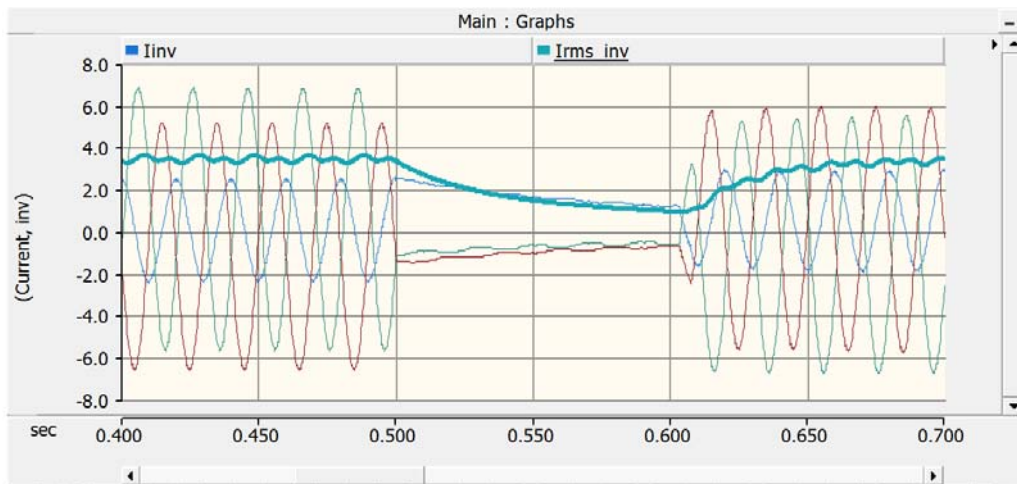

A

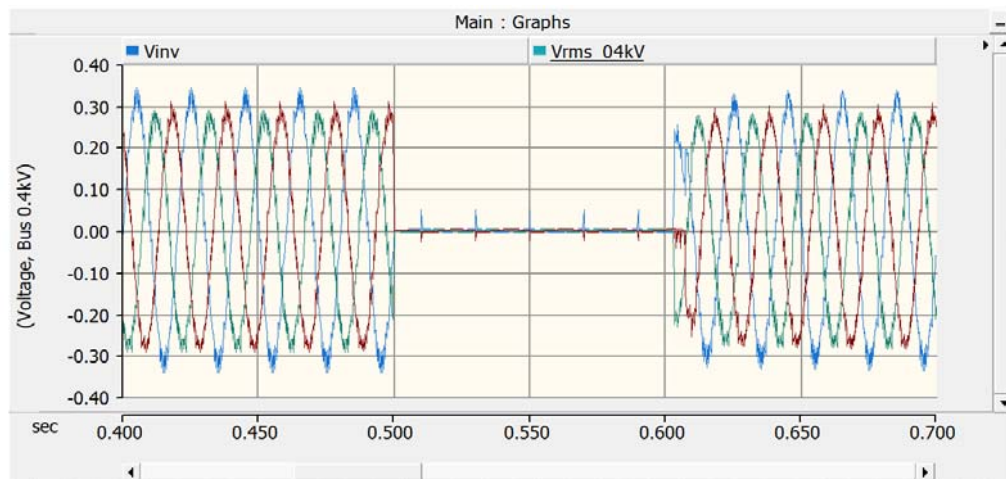

B

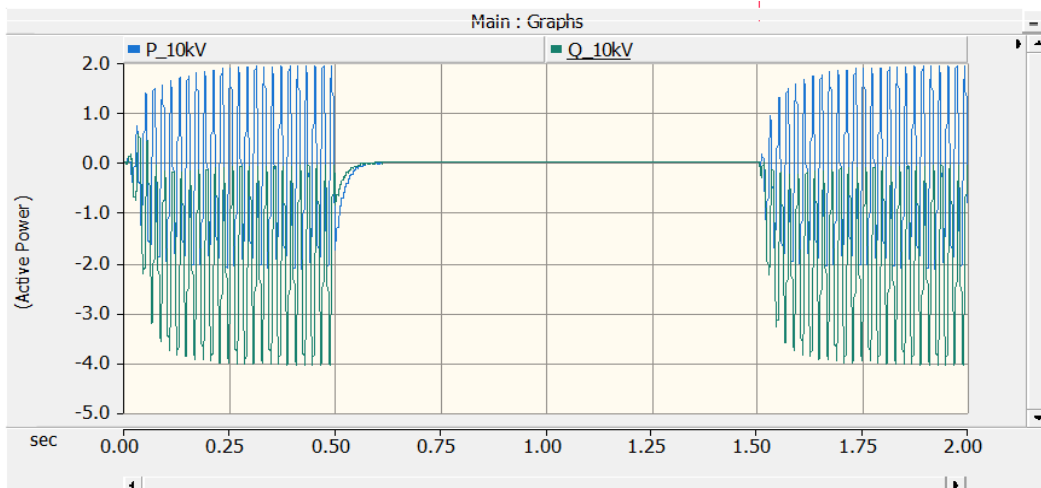

C

Figure 3 – Oscillograms of transient processes with a 3-phase short-circuit fault with a duration of 1 sec on buses substation 10 kV with a connected SPP. A – instantaneous and effective values of currents B – instantaneous and effective values of voltages, C – active values of active and reactive power

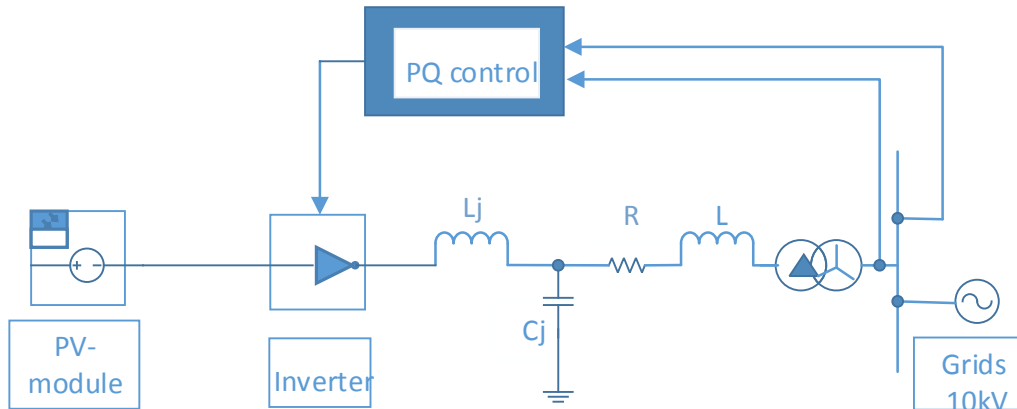

Figure 4 – Block diagram of the Iq controller operation in the SPP system when connected to an external network

$$\begin{cases} L \frac{di_L}{dt} = -R \cdot i_L - K_{FD}(\xi(t)) \cdot u_C + E; \\ C \frac{du_C}{dt} = i_L \cdot K_{FD}(\xi(t)) - \frac{u_C}{R_H}, \end{cases} \quad (5)$$

where i_L is the current in the inductance; u_C - voltage on the filter capacity; $\xi(t)$ - a function that describes the commutation of a diode.

In the matrix form, system (4) is written as

$$\frac{d\bar{X}}{dt} = A(K_F(\xi(t))) \cdot \bar{X} + \bar{B}(i_L).$$

The principle of the Iq regulator operation is to control the external voltage of the network and to regulate the operation of the inverter by generating active and reactive transients in the event of a fault (5).

$$u_{a,b,c} = U_{sa, sb, sc} - (Ri_d + L \frac{di_d}{dt}) \quad (6)$$

The operation of the inverter for regulating the generation of active and reactive power will be performed in accordance with the model in the coordinates dq from the change in the phase of the external current ωLi_q , $-\omega Li_d$ (6).

$$\begin{aligned} u_d &= U_{sd} - \left(Ri_d(t) + L \frac{di_d(t)}{dt} \right) + \omega Li_q(t) \\ u_q &= U_{sq} - \left(Ri_q(t) + L \frac{di_q(t)}{dt} \right) - \omega Li_d(t) \end{aligned} \quad (7)$$

The purpose of voltage regulation at the connection point is to provide the required voltage in accordance with the graph shown in Fig. 1. To do this, Iq controller is used, which determines the current value on the inverter i_m using the system of equations 6.

To determine the currents \bar{X} (i_d , i_q), we use the solution of linear equations in the form:

$$\bar{X}(t) = \bar{Y} \cdot A^{-1}, \quad (8)$$

where \bar{Y} – is the vector of voltage drops in the network between the points of connection of the SPP to the system in the coordinates d, q, \bar{Y} (U_d , U_q); \bar{X} – current vector in the coordinates d, q; A – matrix parameters (step-up transformer, cable, etc.) between the point U_{out} and the point of connection of SPP to the system buses.

$$\begin{cases} Y_d \geq (U_{sd} - U_d) / U_{sdndn}; \\ Y_q = (U_{sq} - U_q) / U_{sqnqn}. \end{cases} \quad (9)$$

The solution of system (8) has the form:

$$\bar{X}(t) = \bar{X}(t + T), \quad (10)$$

where $Y_S = \sqrt{Y_d^2 + Y_q^2}$, determined by the shutdown conditions:

$$\begin{cases} Y_S \geq Y_{Snom} \text{ where } t \equiv (t_0; t_\infty); \\ Y_S = 0 \text{ where } t < 0.4s; \\ Y_S = Y_0 + k \cdot t, \text{ where } k = tg(\Delta U / t). \end{cases} \quad (11)$$

As a result of the developed adaptive algorithm, the necessary level of output voltage of the PV system will be provided in the Iq regulator functioning in order to stabilize the transients of the external power system.

Conclusion. In this paper, some possibilities of distributed generation to regulate voltage and control reactive power were shown, but still many questions require investigation. One of them is economic efficiency, because such an approach increases losses in distribution grid. With significant integration of SES and the absence of a reverse electromechanical connection with the power system, it is necessary to use the development of a voltage regulator at SPP based on the parameters of the external network mode, based on adaptive algorithms for controlling the operation of inverters. The voltage regulator on SPP is implemented in the form of Iq controller, which affects the current of the inverter i_{in} . An algorithm for determining the required current value is proposed using the equation of the current dependence on the voltage drop between the U_{out} point and the SPP connection point to the system buses. In addition, different combinations of control for large and small-scale PV plants are possible to consider as well as an implementation of central control for all renewables in the distributed grid. This direction will be also investigated in the nearest future.

Acknowledgements. This work was carried out with financial support of the Committee of Science of the Ministry of Education and Science of Kazakhstan (grant № 25 contract 29/10/18, №APP-PSC-I-17/006P).

REFERENCES

- [1] Zakon Respubliki Kazahstanot 4 iyulya 2009 goda № 165-IV «O podderzhke ispolzovaniya vozobnovlyaemyih istochnikov energii».
- [2] «Forsayt – 2050» Novyy mir energii i mesto Kazahstana v nem Ministerstvo energetiki Respubliki Kazahstan 2017 g.
- [3] Barkov V.I. Mezhdunarodnaya agroinzhenneriya, 2016, vyipusk 1 57. Nauchno-Tehnicheskii Potentsial Solnechnoy Energetiki Kazahstana. P. 57-62.
- [4] Kamaruzzaman Z.A., A. Mohamed H. Shareef/Effect of grid-connected photovoltaic systems on static and dynamic voltage stability with analysis techniques – a review PRZEGLĄD ELEKTROTECHNICZNY, ISSN 0033-2097, R. 91 NR 6/2015.
- [5] Yuwei Sun, Xujing Tang, Yuanchao Qiu, Yang Wang, Chengqing Yuan, Qizhen Jiang. Research on the Transient Characteristic of Photovoltaics-ship Power System based on PSCAD/EMTDC/4th International Conference on Renewable Energy Research and Applications Palermo, Italy, 22-25 Nov. 2015.
- [6] Erhab Youssef, Rasha M. El Azab, Amr M. Amin / Influence study of concentrated photovoltaic location on voltage stability // International Journal of Smart Grid and Clean Energy. July 2015. Vol. 4, N 3.
- [7] Rakhimova G., Temirova A., Abikayeva M. The need for reform at energy sector republic of Kazakhstan in the context conservation and energy efficiency // Bulletin of national academy of sciences of the republic of Kazakhstan. Vol. 2, N 360. P. 132-136. ISSN 1991-3494. 2016. <http://www.bulletin-science.kz/images/pdf/v20162/v132136.pdf>, <https://doi.org/10.32014/2018.2518-1467>
- [8] Nadirov N.K., Solodova E.V., Kydyralina N.N., Kasymkulov A.K. The basic construction of greenhouses and methods power supply using alternative energy sources // Bulletin of national academy of sciences of the republic of Kazakhstan. 2015. Vol. 3, N 355. P. 88-97. ISSN 1991-3494. <http://www.bulletin-science.kz/images/pdf/v20153/ves92101.pdf>, <https://doi.org/10.32014/2018.2518-1467>

- [9] Tohtibakiev K.K., Dmitriev K.O., Sauhimov A.A., Shokolakova Sh.K. Issledovanie dinamicheskikh karakteristik vetrovoy elektrostantsii pri podklyuchenii k raspredelitelnoy seti // Issledovaniya, rezultaty. 2016. N 3(71). P. 265-272. ISSN 2304-3334-04.
- [10] Postanovlenie Pravitelstva Respubliki Kazahstan ot 19 iyunya 2013 goda № 625. Ob utverzhdenii Elektrosetevyih pravil redaktsiya ot 21 avgusta 2015 goda № 657.
- [11] Yandulskiy A.S., Marchenko A.A., Nesterko A.B. Otsenka dinamicheskikh karakteristik mnogomashinnykh elektroenergeticheskikh sistem na osnove dannykh sistemy monitoringa perehodnykh rezhimov // Nauchnyye trudy VNTU. 2014. N 4.
- [12] WANG Jin, ZHANG Jinhua, HAO Zhiguo. Analysis of Photovoltaic Power Generation System Low Voltage Ride through Control during Asymmetric Fault // 2016 China International Conference on Electricity Distribution (CICED 2016) Xi'an, 10-13 Aug, 2016.
- [13] Thanomsat N., Plangklang B. Analysis of Power Output Impact on PV rooftop system under Different Installation Positions by PSCAD // Energy Procedia. 2016. 89. P. 149-159.
- [14] Microgrid control principles in island mode operation Conference Paper (PDF Available) June 2013 with 1,357 Reads. DOI: 10.1109/PTC.2013.6652453 Conference: Conference: POWERTECH 2013, At Grenoble, France <https://www.researchgate.net/publication/258960218>
- [15] Vinogradov A.Yu., Gerasimov A.S., Kozlov A.V. Primenenie upravlyaemykh ustroystv kompensatsii reaktivnoy moschnosti v EES Rossii dlya postroeniya intellektualnoy elektroenergeticheskoy sistemy // Izvestiya NTTs Edinoy energeticheskoy sistemy v Internetе. ISSN 2307-261X.
- [16] Issledovanie vliyaniya VIE pri suschestvuyuschih vozmozhnostyah EES Kazahstana (uroven 2015–2020 gg.) // Energetika. 2016. N 1(56).
- [17] Trofimov G.G., Zhivaeva O.P. Rabota vozobnovlyаемykh istochnikov energii v energosisteme // Energetika. 2015. N 2(53). P. 25-33.
- [18] Kalashnik V.I., Pomogaev Yu.M. Avtonomnyy invertor napryazheniya // Mehanizatsiya i Elektrifikatsiya selskogo hozyaystva. 2013. N 5. P. 20-22.
- [19] Kalashnik V.I., Cheremisinova N.A. Tsifrovoy regulyator napryazheniya // Tehnika v selskom hozyaystve. 2012. N 4. P. 15-17.
- [20] Bokenbaev Zh., Tukenov A., Bapin E., Doroshin G., Muhamedin Zh. Osnovnyie bareryi pri integratsii VIE v edinuyu energosistemu RK i rekomendatsii po ih resheniyu // Prilozhenie k zhurnalu «Energetika» -2015. N 1(52). P. 34-39.

С. А. Кешуов¹, Ш. К. Шоколакова¹, А. А. Саухимов², Е. Шувалова³

¹Казахский национальный аграрный университет, Алматы, Казахстан,

²Алматинский Университет Энергетики и Связи, Алматы, Казахстан,

³Таллинский Технический Университет, Таллин, Эстония

МВТ ҚУАТТЫЛЫҚТАҒЫ КҮНЭЛЕКТРСТАНЦИЯСЫН ИНТЕГРАЛДАУ КЕЗІНДЕГІ ТАРАТУШЫ ЖЕЛІЛЕРДЕГІ КЕРНЕУ ТҰРАҚТЫЛЫҒЫНЫҢ ЗЕРТТЕУІ

Аннотация. Қазақстанда жаңартылатын энергия көздерін енгізуді ынталандыру бойынша бірқатар шаралар қабылданды, олардың біреуі күнэнергиясы болып табылады [1, 2]. Көптеген жел және күнэлектрстанциялары (КЭС) инерциалды жауап беруді немесе статистиканы бақылауды қамтамасыз етпейді. Қайта кернеу кернеуінің инверторы сыртқы электрмен жабдықтау жүйесінің кернеуімен кері байланыс жоқ. СЭС-нің электрэнергиясын өндіруі, әдетте, тек күн радиациясының функциясы болып табылады және желі жұмысының параметрлеріне байланысты емес [3]. Осыған байланысты, инверторларды басқаруға бейімделген контроллерлерді режимнің параметрлерін өзгертуге байланысты [4, 5] енгізу мәселесі өзекті болып табылады. Жаңартылатын энергия көздерін жоғары қуаттылықты торға интеграциялаудың негізгі қиындықтары жүйені жоспарлау және басқару болып табылады. Жүйеге әсерді зерттеу үшін сценарийлер жоғары немесе төмен жүктемеден, жоғары пропорциядан немесе жел/күн энергиясының жоқтығына байланысты. Әрбір жағдайда шиналардың кернеуі рұқсат етілген лимиттерге, белсенді және реактивті қуатты нағынын бөлу, сондай-ақ трансформатордағы, электржелілерінде, генераторлардағы және басқада құрамдас бөліктеріндегі шығындардың есептелуі үшін есептеледі және тексеріледі. Осы мақалада белгіленген қуаты 2 МВт болатын Қапшағай күнэлектрстанциясының мысалында өтпелі режимдерді модельдеу бойынша зерттеулер нәтижелерін ұсынамыз. PSCad виртуалды компьютерлік модельде 10 кВ-тық шиналарда қысқа тұйықталу жағдайында кернеу тұрақтылығыталданды, фотоэлектрлік жүйені басқару үшін интеллектуалды контроллерді қолдану үшін алгоритмдермен механизмдер әзірленді.

С. А. Кешуов¹, Ш. К. Шоколакова¹, А. А. Саухимов², Е. Шувалова³

¹Казахский национальный аграрный университет, Алматы, Казахстан,

²Алматинский университет энергетики и связи, Алматы, Казахстан,

³Таллинский технический университет, Таллин, Эстония

ИССЛЕДОВАНИЕ СТАБИЛЬНОСТИ НАПРЯЖЕНИЯ В РАСПРЕДЕЛИТЕЛЬНЫХ СЕТЯХ ПРИ ИНТЕГРАЦИИ СОЛНЕЧНОЙ ЭЛЕКТРОСТАНЦИИ МОЩНОСТЬЮ 2 МВт

Аннотация. В Казахстане предпринят ряд мер по стимулированию ввода возобновляемых источников энергии (ВИЭ), одним из которых является солнечная энергетика [1, 2]. Большинство ветровых и солнечных электростанций (СЭС) не обеспечивают инерционный отклик или контроль статизма. Преобразовательные инверторы напряжения не имеют обратной связи с напряжением системы внешнего электроснабжения. Генерация мощности СЭС, как правило, является только функцией солнечного излучения и не зависит от режимных параметров сети [3]. В связи с этим, актуальным является вопрос внедрения адаптивных контроллеров по управлению инверторами в зависимости от изменения параметров режима [4, 5]. Ключевыми трудностями при интеграции больших мощностей генерации ВИЭ в энергосистему являются планирование и управление системой. Сценарии для изучения воздействия на систему зависят от высокой или низкой нагрузки, высокой доли или отсутствия ветряной /солнечной энергии. Для каждого случая рассчитывается напряжение на шине и проверяется на соответствие допустимым пределам, проводится расчет потокораспределения активной и реактивной мощности, а также потерь в трансформаторе, на ЛЭП, генераторах и других компонентах. В настоящей работе приведены результаты исследований по моделированию переходных режимов на примере Капшагайской солнечной станции (СЭС) установленной мощностью 2 МВт. В виртуальной модели ПК PSCad проанализирована стабильность напряжения при возникновении короткого замыкания на шинах 10 кВ, разработаны алгоритмы и механизмы по использованию интеллектуального регулятора для управления фотовольтаической системой.

Ключевые слова: распределенная генерация, стабильность напряжения, интеграция СЭС, переходные процессы, ток короткого замыкания.

Information about authors:

Keshuov S. A. – JSC KazNAU, Energy saving and automation chair, professor, academician NAS of RK, d.t.s.; keshuov@mail.ru

Shokolakova Sh. K. – JSC «KazNaU», candidate PhD; shinara.shokolakova@mail.ru; <https://orcid.org/0000-0002-7332-4343>

Saukhimov A. A. – JSC «AUPET», Head of Institute of Electric Power and Electrical Engineering, PhD; sauchimov@gmail.com; <https://orcid.org/0000-0002-7506-9200>

Shuvalova J. – Tallinn University_of Technology, Department of Electrical Power Engineering and Mechatronics, Senior Lecturer; jelena.suvalova@ttu.ee; <https://orcid.org/0000-0002-6410-9828>

**Publication Ethics and Publication Malpractice
in the journals of the National Academy of Sciences of the Republic of Kazakhstan**

For information on Ethics in publishing and Ethical guidelines for journal publication see <http://www.elsevier.com/publishingethics> and <http://www.elsevier.com/journal-authors/ethics>.

Submission of an article to the National Academy of Sciences of the Republic of Kazakhstan implies that the described work has not been published previously (except in the form of an abstract or as part of a published lecture or academic thesis or as an electronic preprint, see <http://www.elsevier.com/postingpolicy>), that it is not under consideration for publication elsewhere, that its publication is approved by all authors and tacitly or explicitly by the responsible authorities where the work was carried out, and that, if accepted, it will not be published elsewhere in the same form, in English or in any other language, including electronically without the written consent of the copyright-holder. In particular, translations into English of papers already published in another language are not accepted.

No other forms of scientific misconduct are allowed, such as plagiarism, falsification, fraudulent data, incorrect interpretation of other works, incorrect citations, etc. The National Academy of Sciences of the Republic of Kazakhstan follows the Code of Conduct of the Committee on Publication Ethics (COPE), and follows the COPE Flowcharts for Resolving Cases of Suspected Misconduct (http://publicationethics.org/files/u2/New_Code.pdf). To verify originality, your article may be checked by the Cross Check originality detection service <http://www.elsevier.com/editors/plagdetect>.

The authors are obliged to participate in peer review process and be ready to provide corrections, clarifications, retractions and apologies when needed. All authors of a paper should have significantly contributed to the research.

The reviewers should provide objective judgments and should point out relevant published works which are not yet cited. Reviewed articles should be treated confidentially. The reviewers will be chosen in such a way that there is no conflict of interests with respect to the research, the authors and/or the research funders.

The editors have complete responsibility and authority to reject or accept a paper, and they will only accept a paper when reasonably certain. They will preserve anonymity of reviewers and promote publication of corrections, clarifications, retractions and apologies when needed. The acceptance of a paper automatically implies the copyright transfer to the National Academy of Sciences of the Republic of Kazakhstan.

The Editorial Board of the National Academy of Sciences of the Republic of Kazakhstan will monitor and safeguard publishing ethics.

Правила оформления статьи для публикации в журнале смотреть на сайте:

www.nauka-nanrk.kz

ISSN 2518-1467 (Online), ISSN 1991-3494 (Print)

<http://www.bulletin-science.kz/index.php/ru/>

Редакторы *М. С. Ахметова, Т. М. Апендиев, Д. С. Аленов*
Верстка на компьютере *Д. Н. Калкабековой*

Подписано в печать 29.11.2018.
Формат 60x881/8. Бумага офсетная. Печать – ризограф.
16,5 п.л. Тираж 500. Заказ 6.